

# EXTRUSION

# VALCO

## MISC SECTIONS

15012

0.422Kg/m

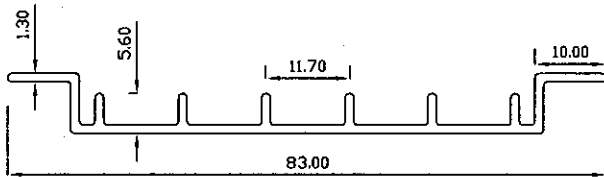

15020

1.918Kg/m

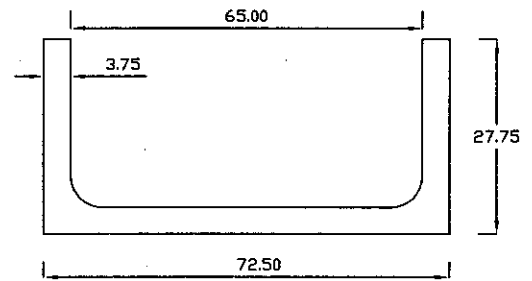

15038

0.410Kg/m

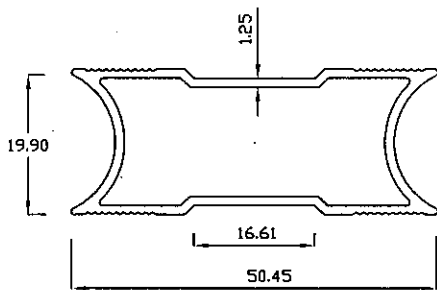

15042

0.341Kg/m

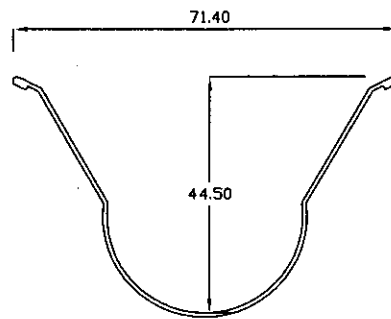

15043

0.292Kg/m

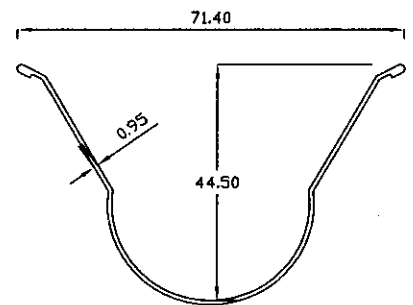

16002

1.777Kg/m

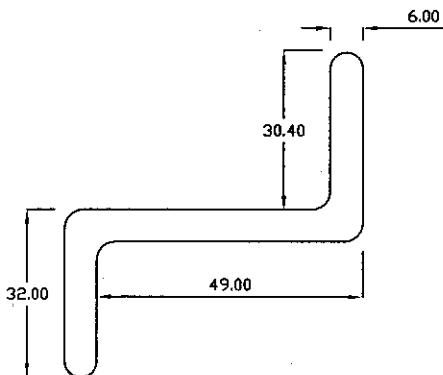

16031

0.781Kg/m

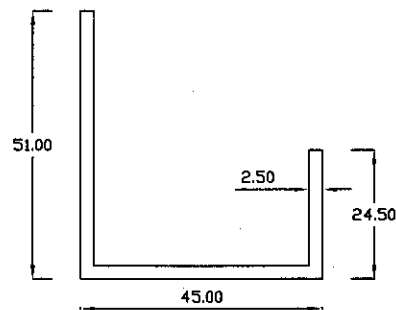

16034

0.093Kg/m

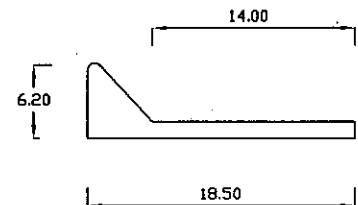

# EXTRUSION

# VALCO

## MISC SECTIONS

17121 0.211Kg/m

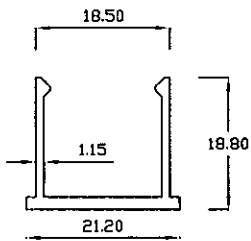

17122 0.444Kg/m

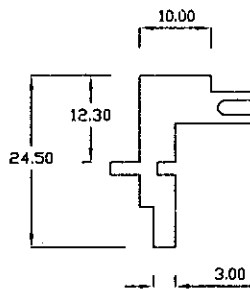

17123 1.681Kg/m

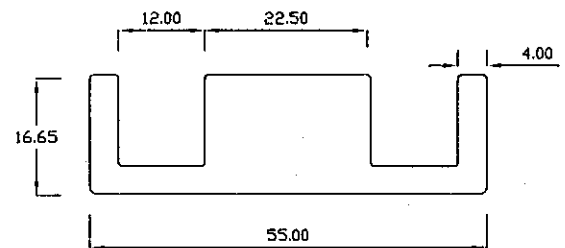

17125 0.875Kg/m

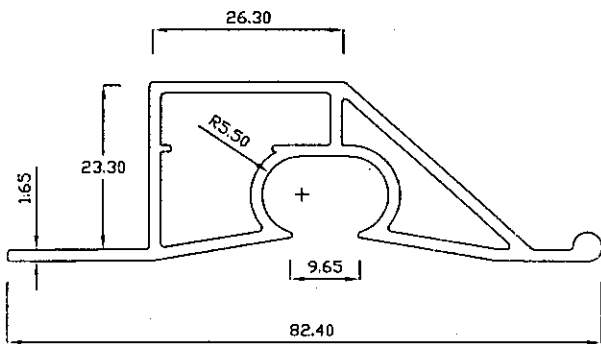

17130 3.118Kg/m

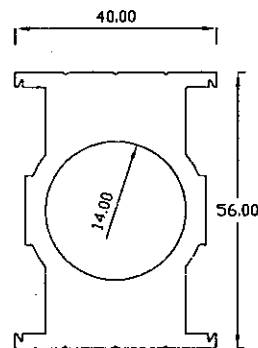

17131 3.125Kg/m

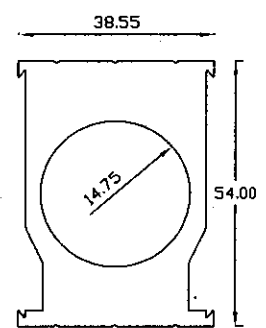

17133 0.850Kg/m

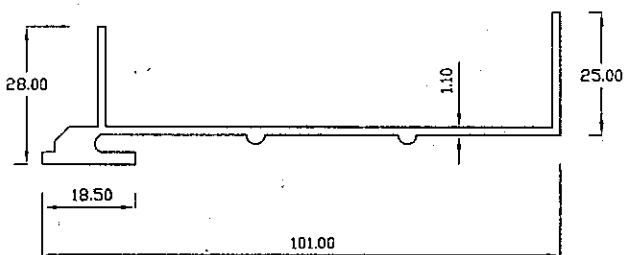

17134 0.316Kg/m

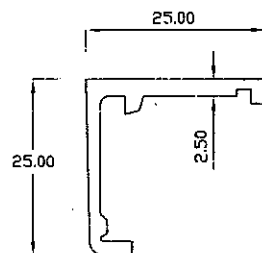

17148 0.195Kg/m

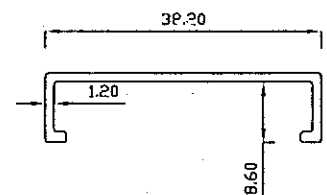

# EXTRUSION

# VALCO

## MISC SECTIONS

17139

3.169Kg/m

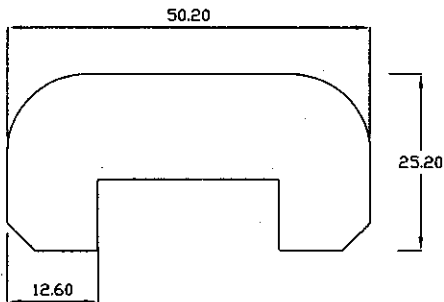

17149

2.967Kg/m

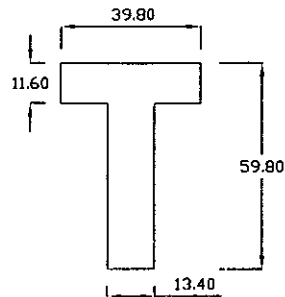

17150

0.648Kg/m

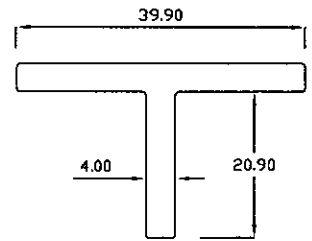

17135

0.652Kg/m

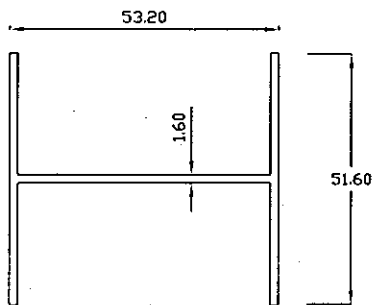

17151

0.721Kg/m

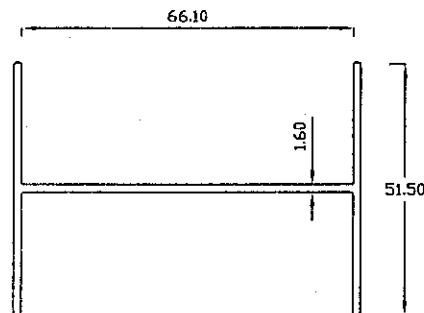

17152

0.686Kg/m

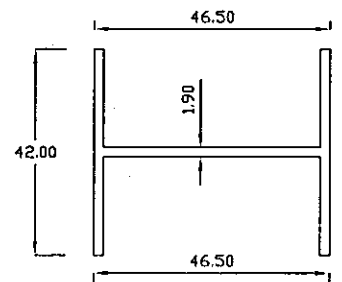

17156

1.299Kg/m

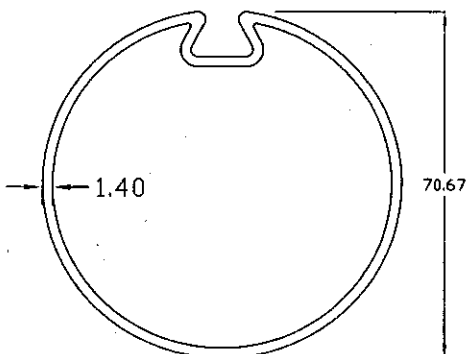

17160

0.401Kg/m

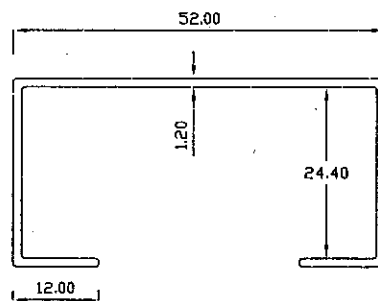

# EXTRUSION

# VALCO

## MISC SECTIONS

17161 1.196Kg/m

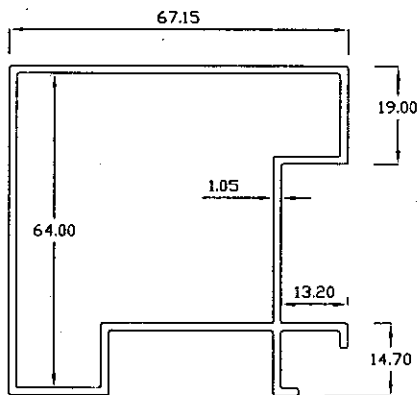

17163 0.664Kg/m

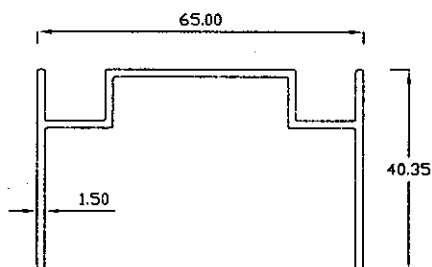

17164 0.780Kg/m

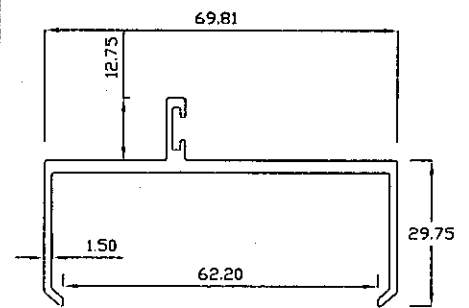

17166 0.998Kg/m

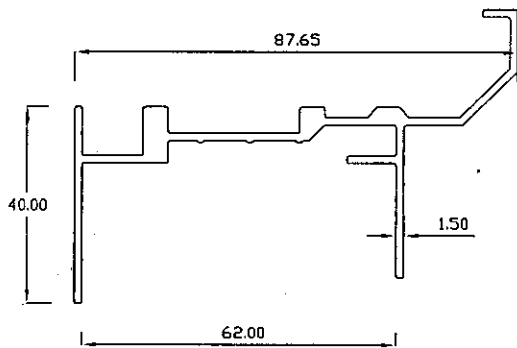

17165 0.842Kg/m

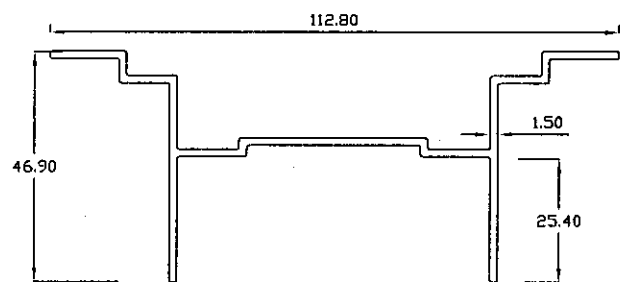

17162 0.528Kg/m

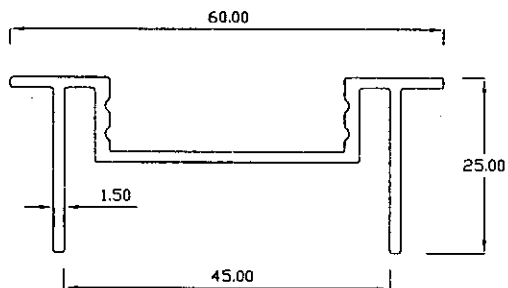

17167 0.538Kg/m

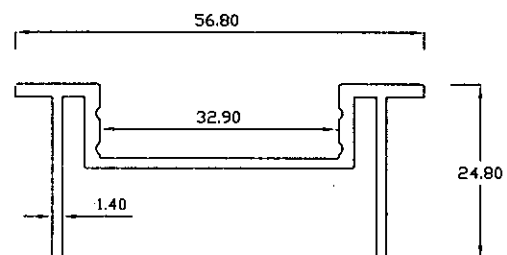

# EXTRUSION

# VALCO

## MISC SECTIONS

17168 0.105Kg/m

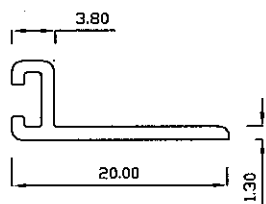

17171 0.152Kg/m

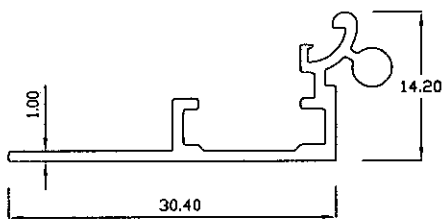

17172 0.184Kg/m

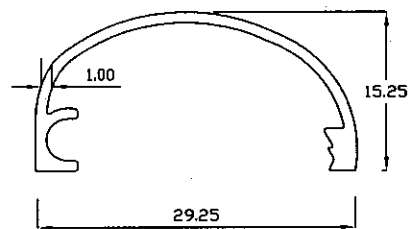

17173 0.378Kg/m

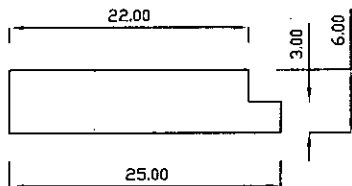

17174 0.381Kg/m

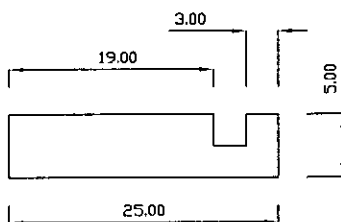

17175 0.841Kg/m

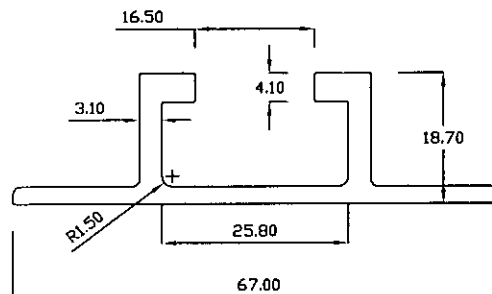

17186 1.271Kg/m

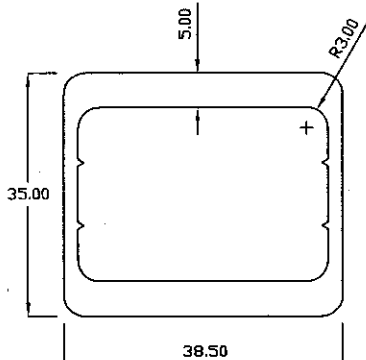

17189 0.192Kg/m

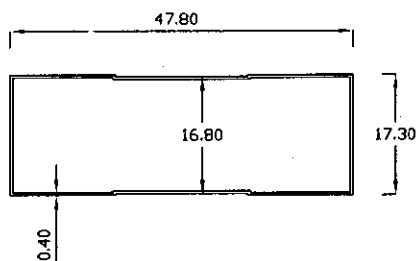

17192 0.353Kg/m

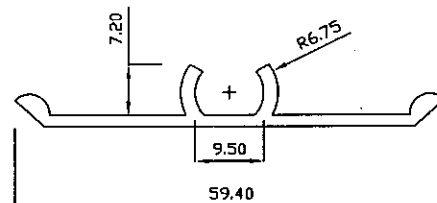

# EXTRUSION

# VALCO

## MISC SECTIONS

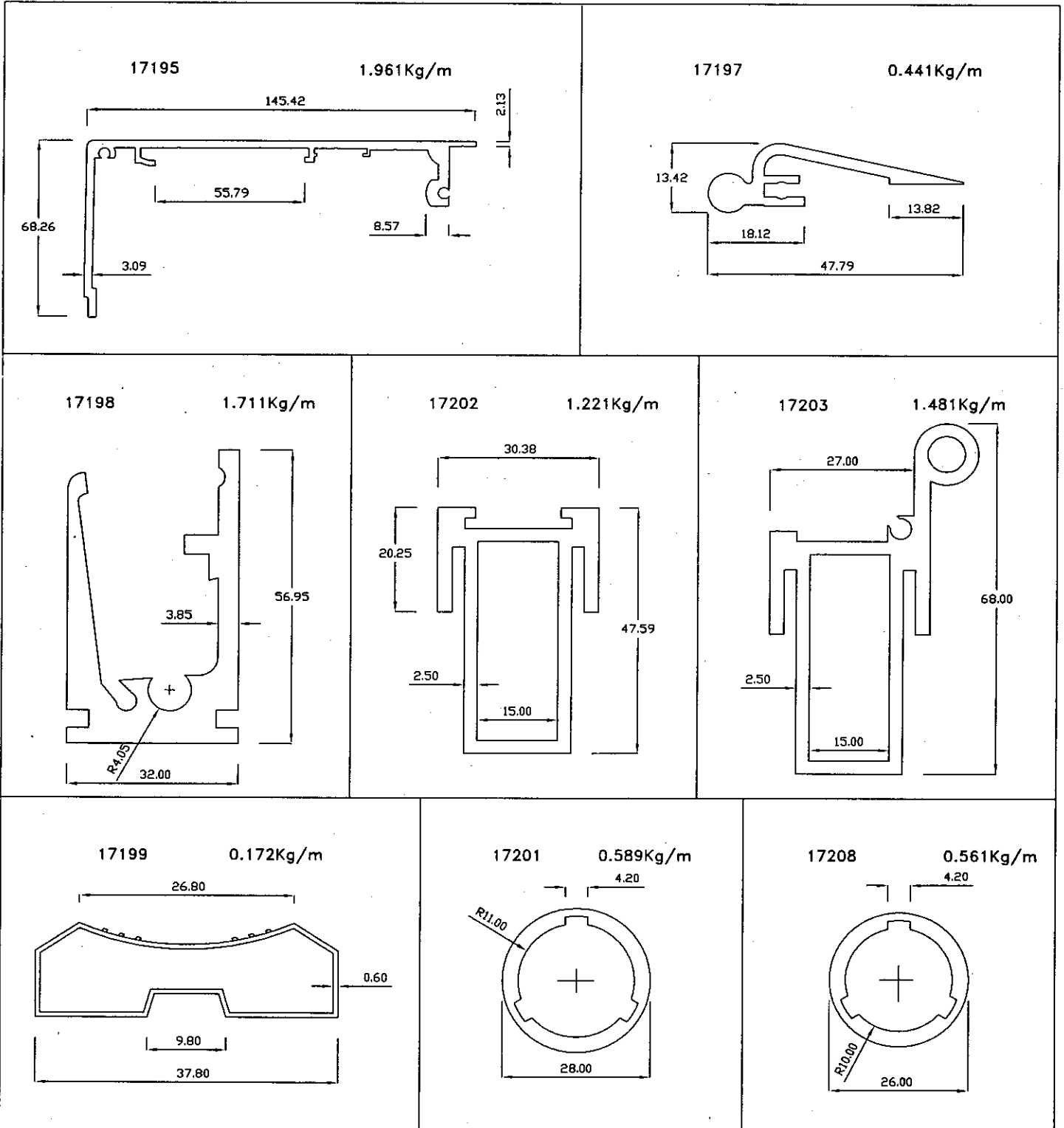

# EXTRUSION

# VALCO

## MISC SECTIONS

17204

0.803Kg/m

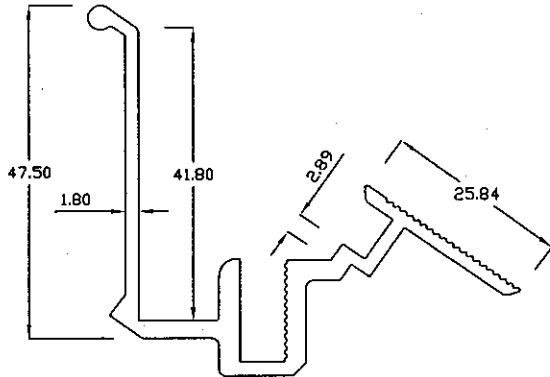

17221

2.136Kg/m

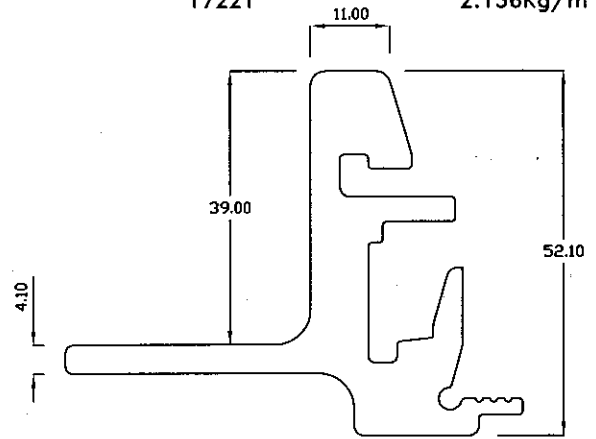

17206

0.682Kg/m

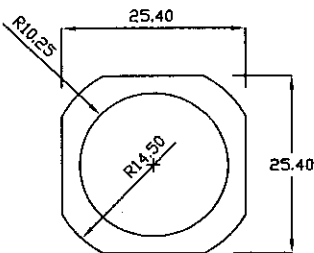

17207

0.235Kg/m

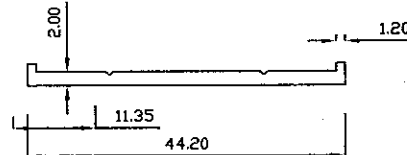

17210

0.635Kg/m

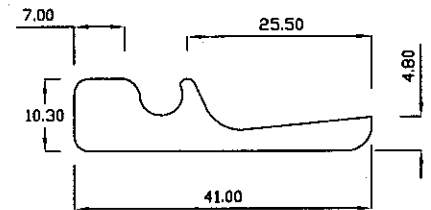

17209

0.94Kg/m

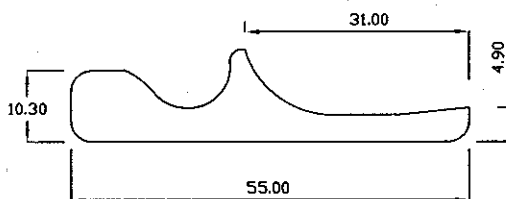

17211

0.375Kg/m

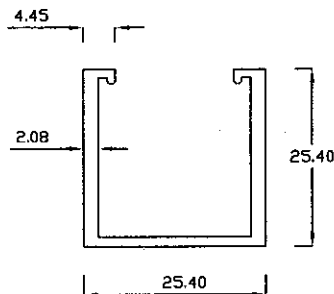

17212

0.380Kg/m

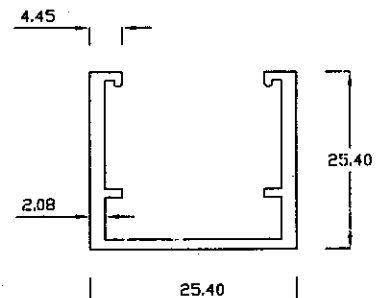

# EXTRUSION

# VALCO

## MISC SECTIONS

17227

0.310Kg/m

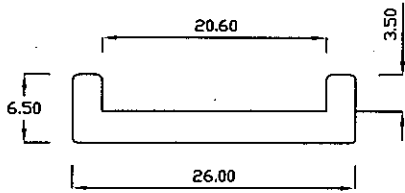

17229

0.429Kg/m

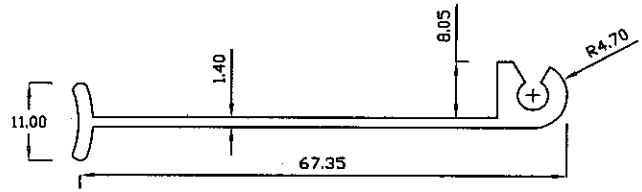

17232

0.284Kg/m

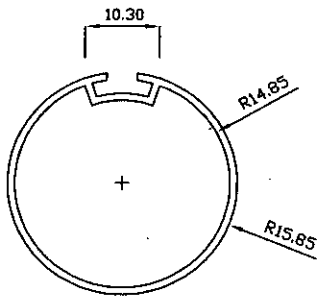

17233

0.265Kg/m

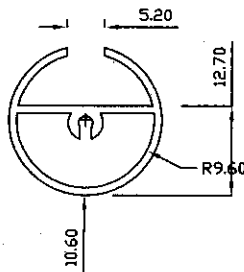

17235

1.03Kg/m

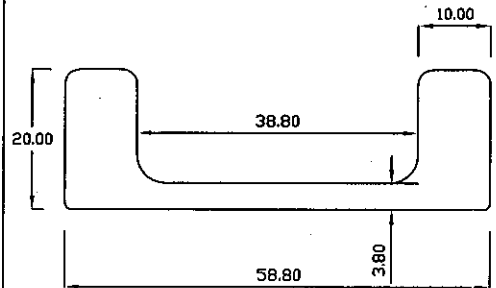

17169

0.098Kg/m

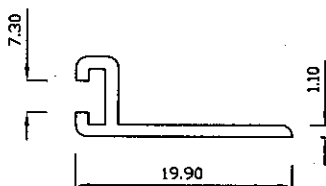

17176

0.290Kg/m

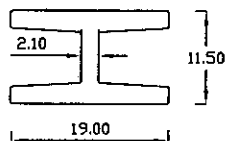

17215

1.105Kg/m

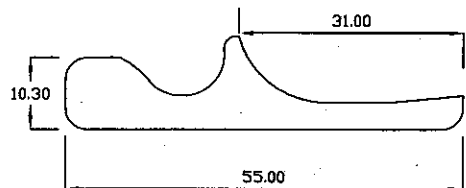

# EXTRUSION

# VALCO

## MISC SECTIONS

17251

1.015Kg/m

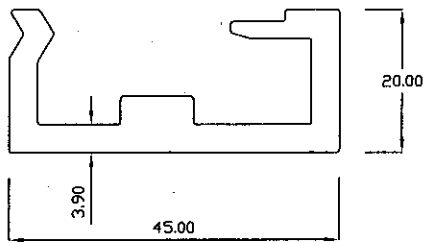

17253

1.785Kg/m

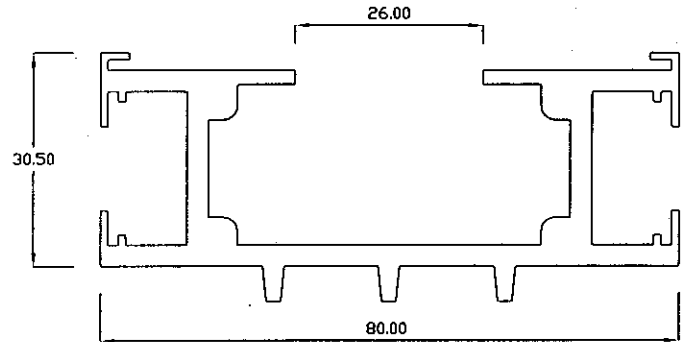

17255

1.415Kg/m

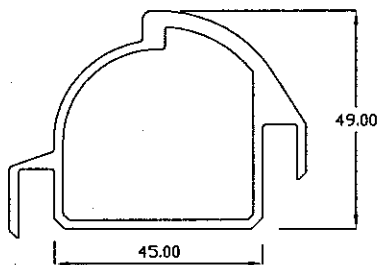

17256

2.155Kg/m

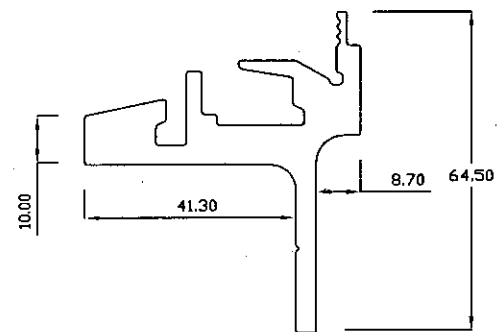

17257

1.355Kg/m

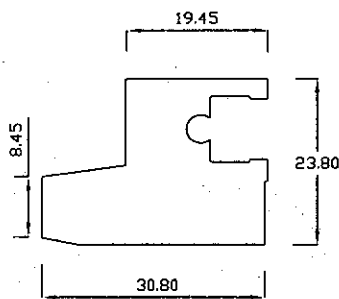

17258

1.215Kg/m

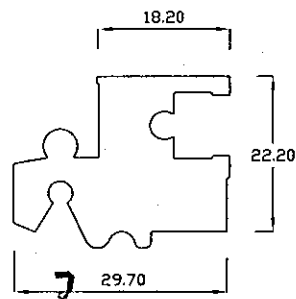

17260

0.255Kg/m

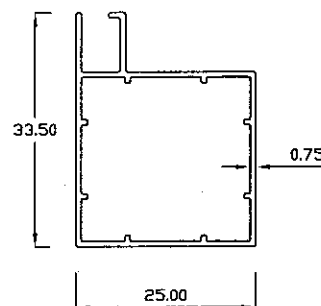

17261

0.295Kg/m

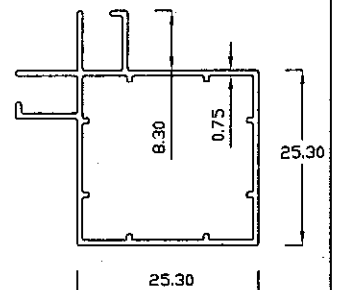

# EXTRUSION

# VALCO

## MISC SECTIONS

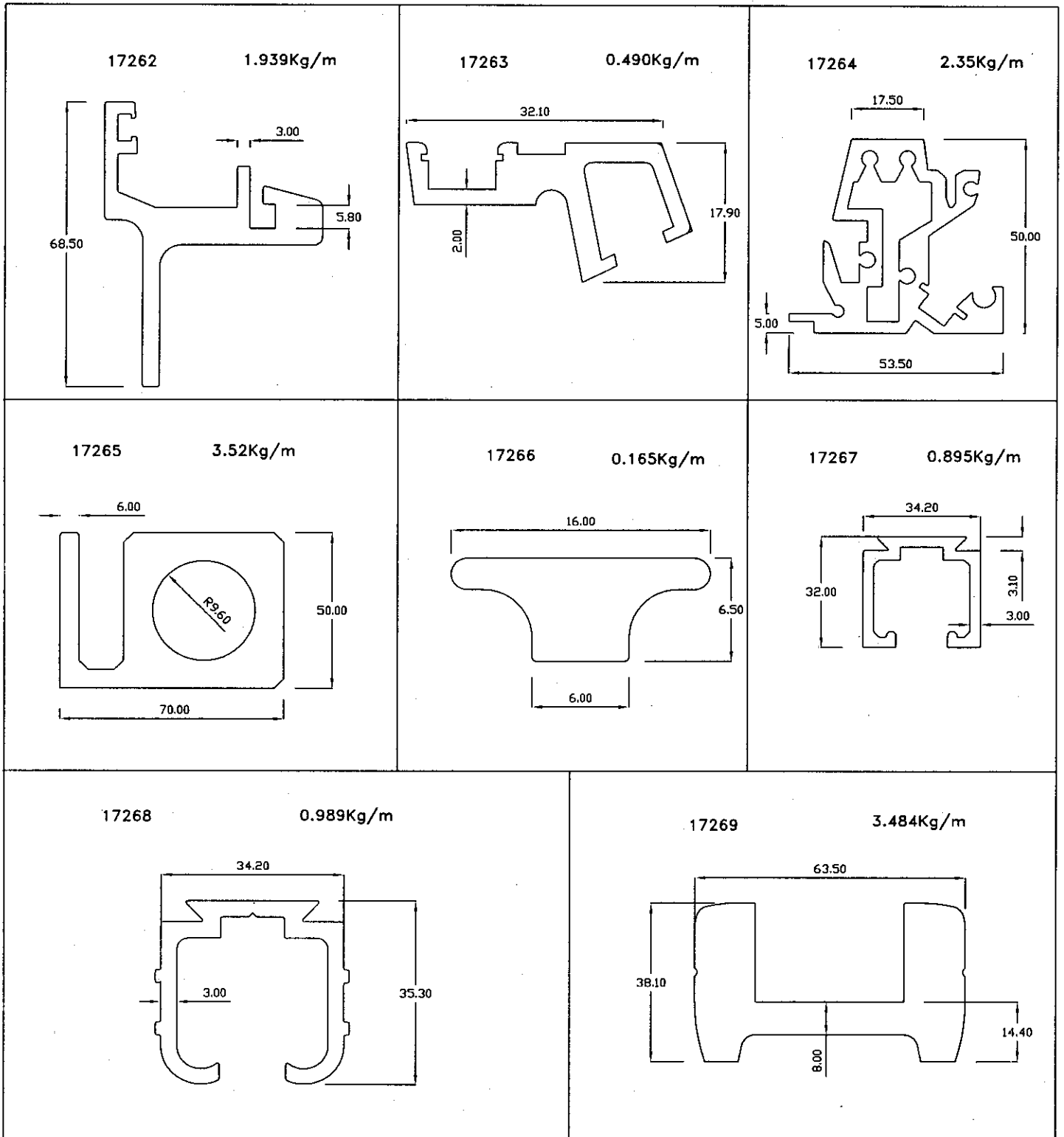

# EXTRUSION

# VALCO

## MISC SECTIONS

17271

0.333Kg/m

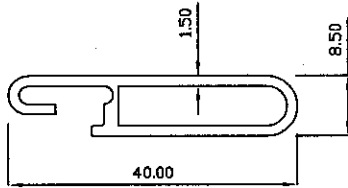

17272

0.544Kg/m

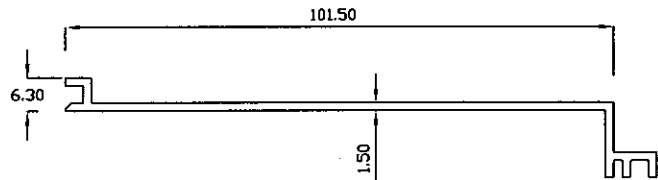

17273

0.178Kg/m

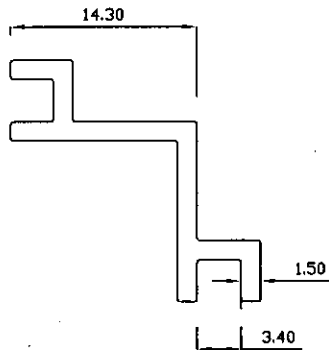

17276

0.70Kg/m

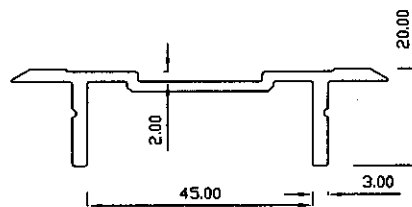

17277

2.60Kg/m

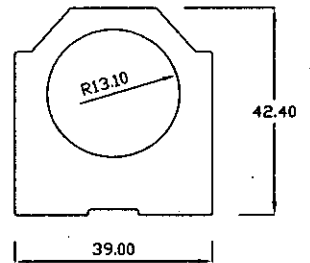

17279

0.835Kg/m

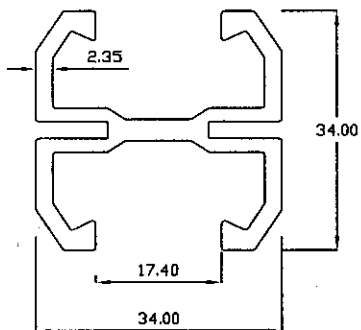

17281

1.850Kg/m

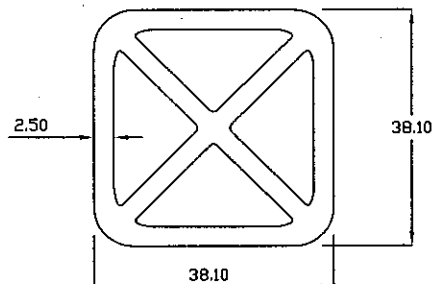

17282

3.90Kg/m

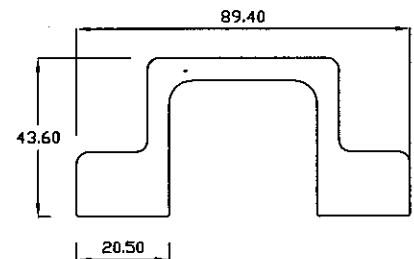

# EXTRUSION

# VALCO

## MISC SECTIONS

17283 4.50Kg/m

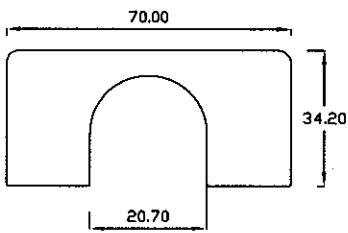

17284 3.40Kg/m

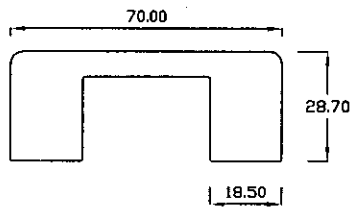

17285 0.931Kg/m

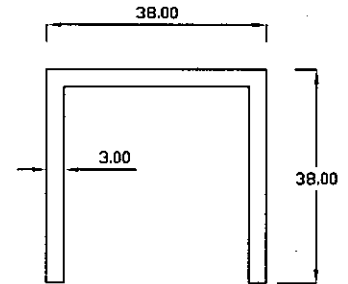

17286 0.218Kg/m

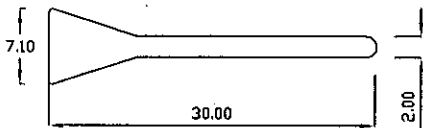

17401 0.520Kg/m

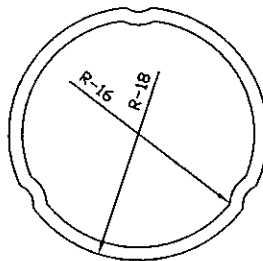

17402 0.110Kg/m

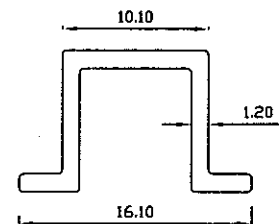

17403 0.935Kg/m

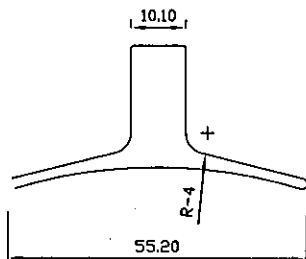

17405 1.32Kg/m

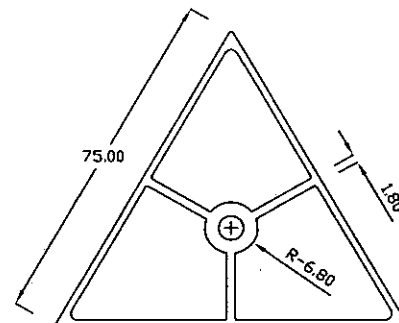

# EXTRUSION

# VALCO

## MISC SECTIONS

17296

0.265Kg/m

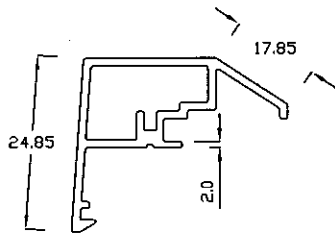

17408

0.300Kg/m

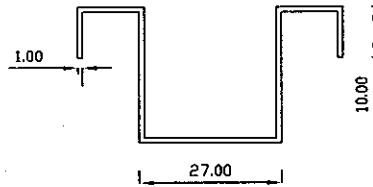

17414

0.205Kg/m

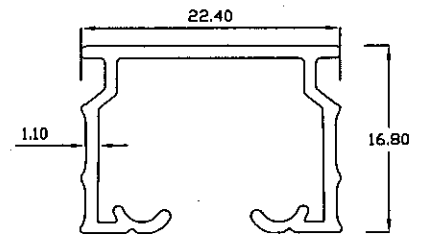

17416

0.330Kg/m

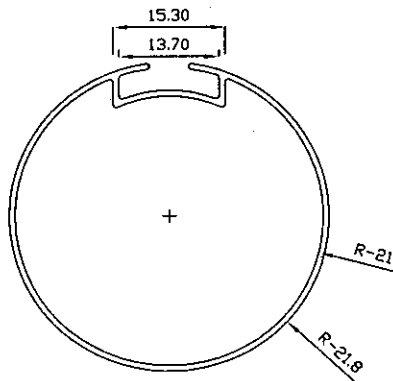

17418

0.928Kg/m

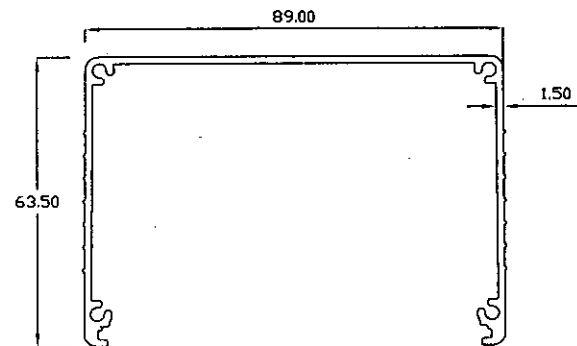

17419

1.97Kg/m

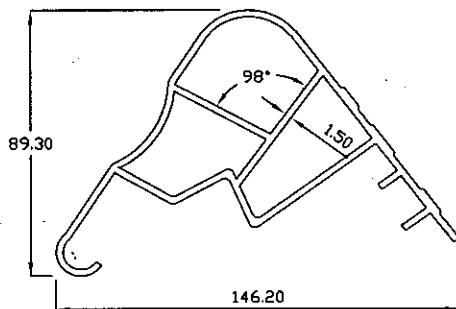

17421

5.220Kg/m

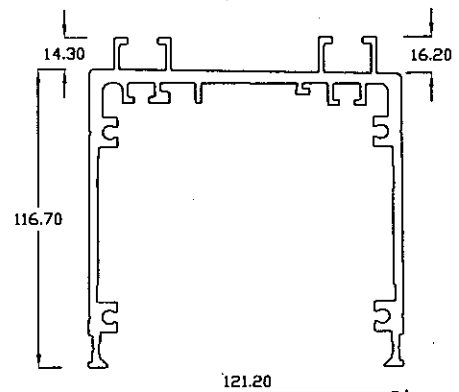

# EXTRUSION

# VALCO

## MISC SECTIONS

17422

1.86Kg/m

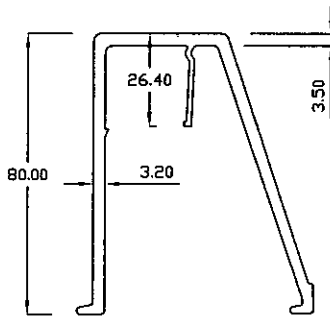

17423

0.900Kg/m

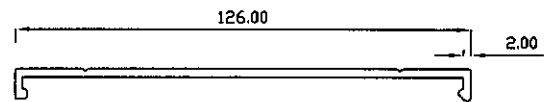

17453

1.310Kg/m

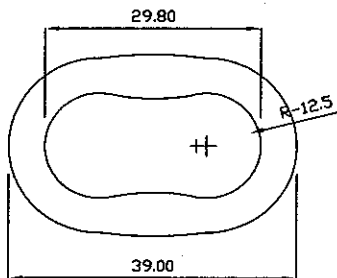

17527

2068Kg/m

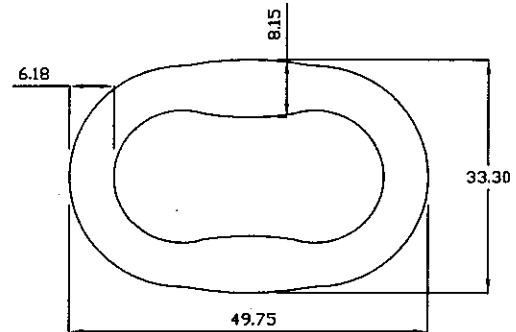

17455

0.000Kg/m

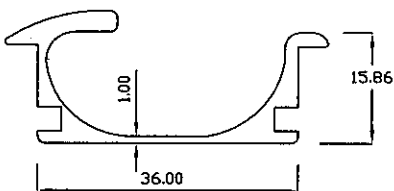

17456

0.625Kg/m

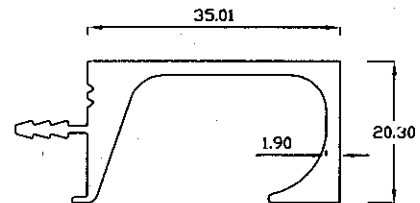

# EXTRUSION

# VALCO

## MISC SECTIONS

17460

6.984Kg/m

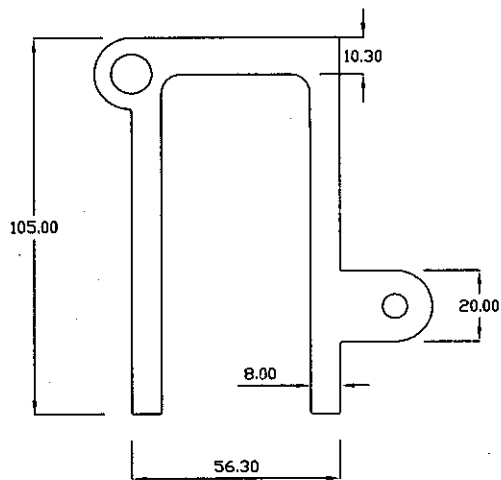

17461

4.741Kg/m

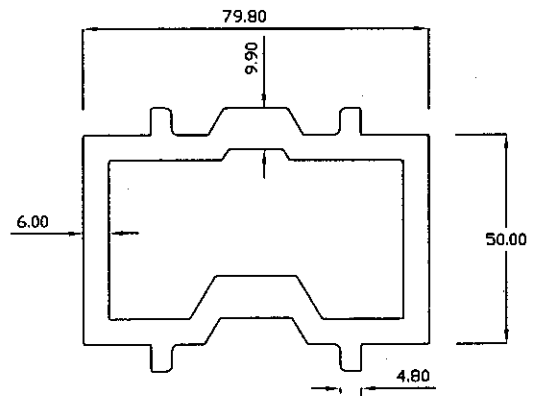

17465

1.027Kg/m

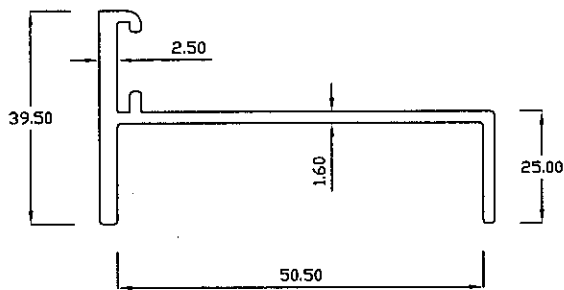

17466

1.744Kg/m

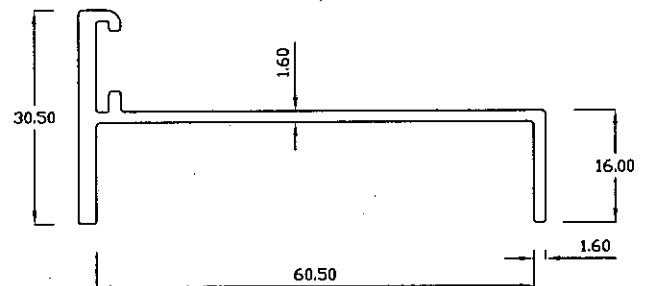

17467

0.868Kg/m

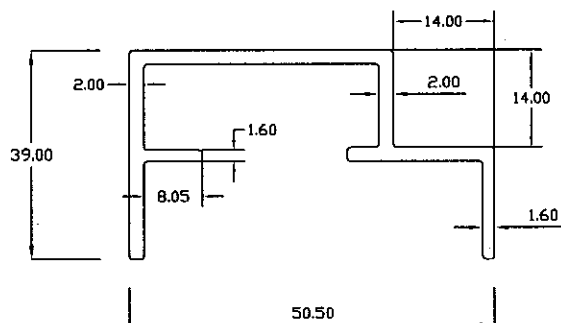

17468

0.961Kg/m

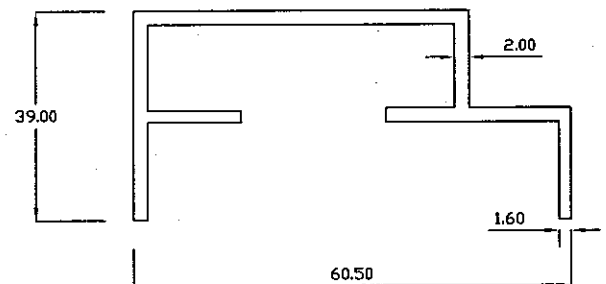

# EXTRUSION

# VALCO

## MISC SECTIONS

17476

0.835Kg/m

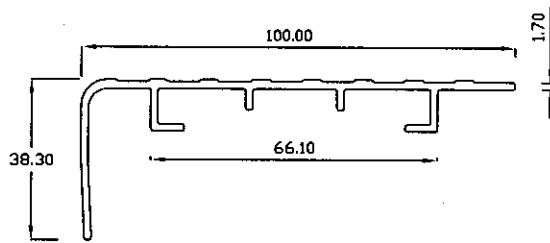

17477

2.467Kg/m

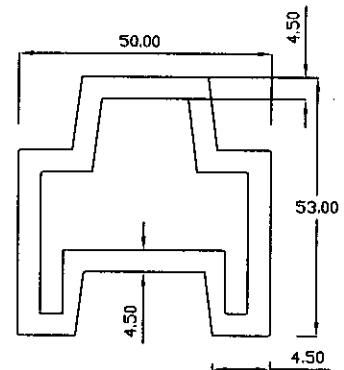

17479

1.583Kg/m

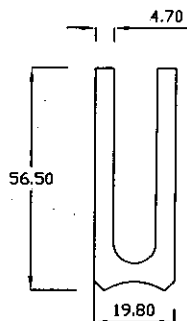

17480

1.057Kg/m

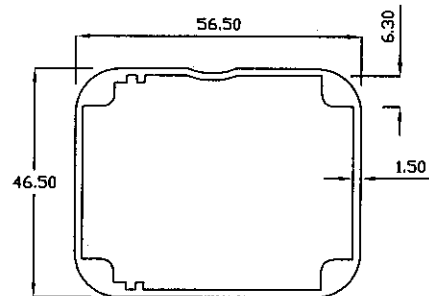

17473

1.273Kg/m

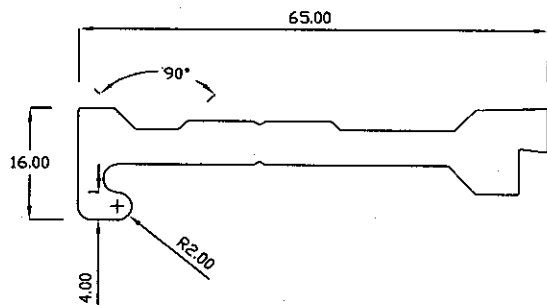

17474

1.20Kg/m

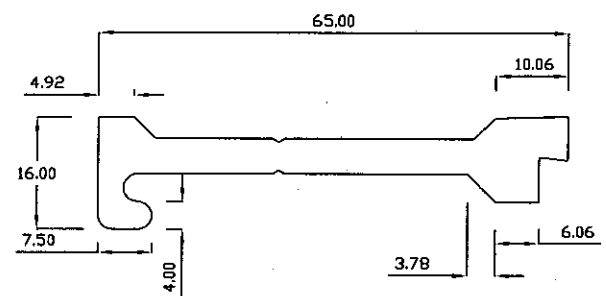

# EXTRUSION

# VALCO

## MISC SECTIONS

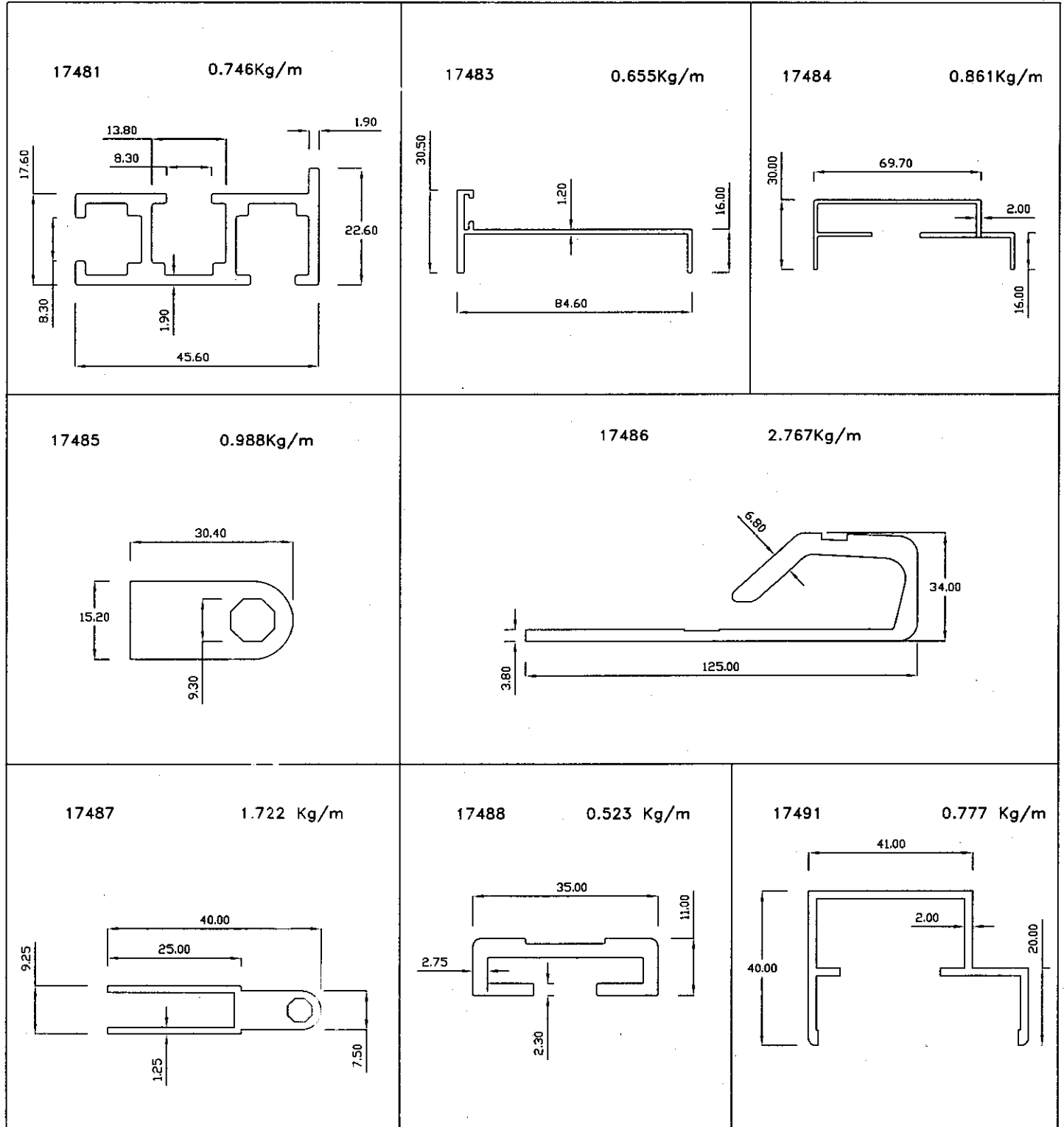

# EXTRUSION

# VALCO

## MISC SECTIONS

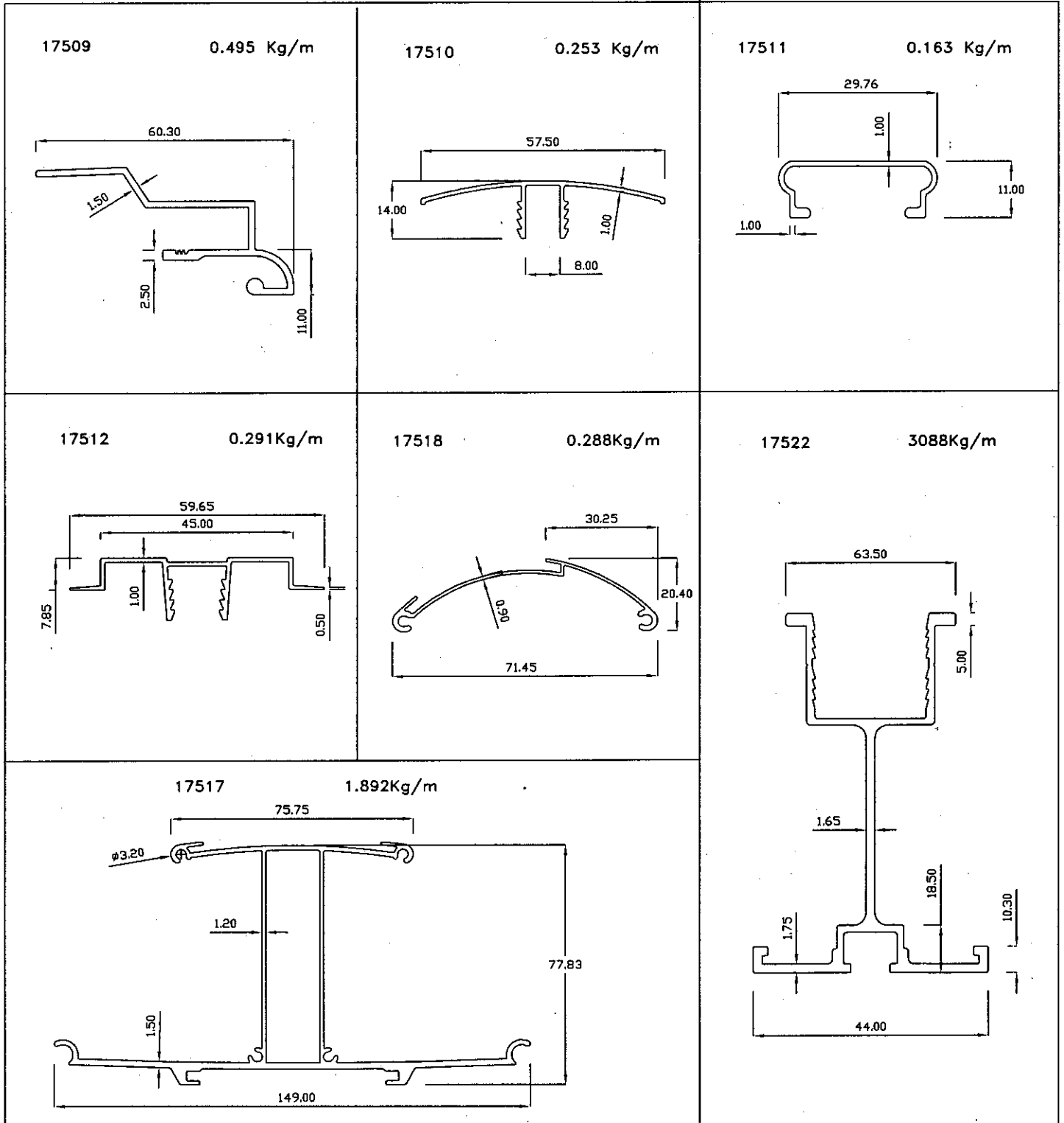

# EXTRUSION

# VALCO

## MISC SECTIONS

17523 1.829Kg/m

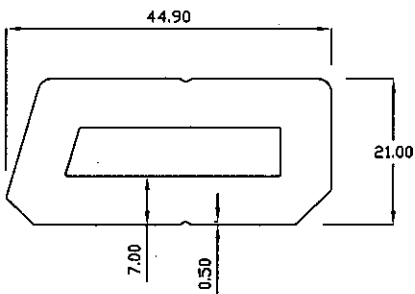

17524 0.194Kg/m

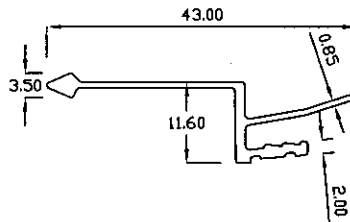

17525 0.130Kg/m

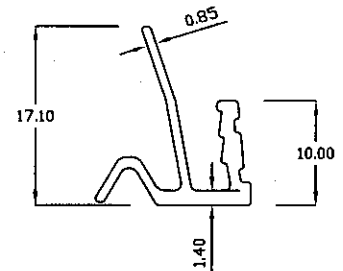

17526 0.702Kg/m

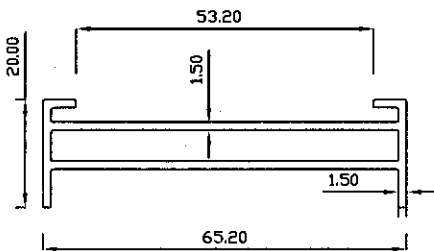

17528 0.571Kg/m

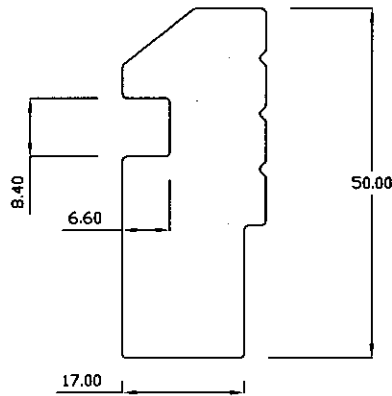

17529 1.829Kg/m

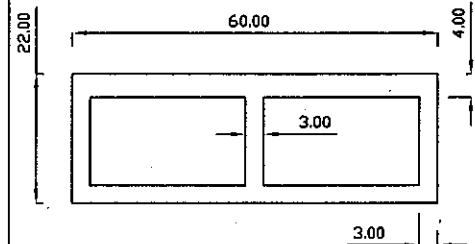

17530 1.752Kg/m

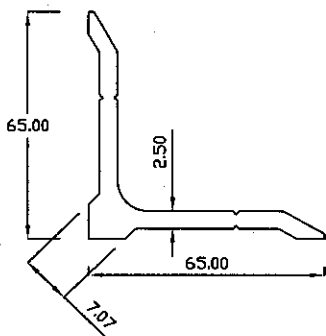

17532 0.127Kg/m

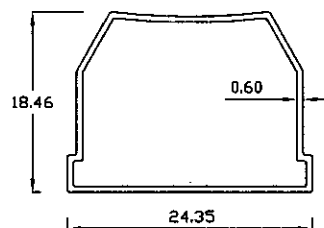

17541 0.446Kg/m

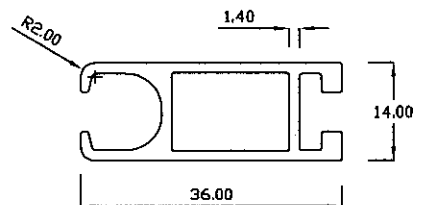

# EXTRUSION

# VALCO

## MISC SECTIONS

17542

1.086Kg/m

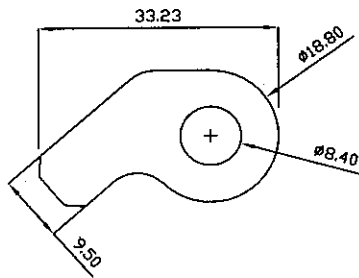

17551

0.265Kg/m

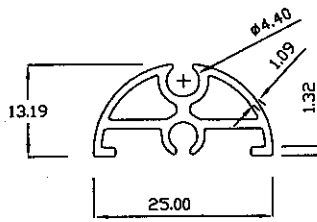

17552

0.381Kg/m

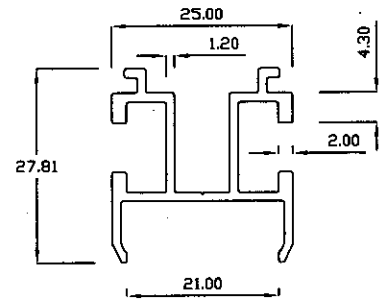

17553

0.394Kg/m

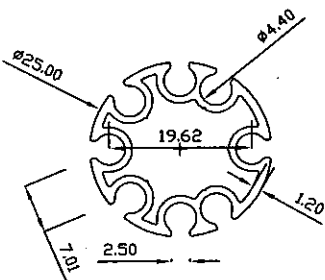

17554

0.067Kg/m

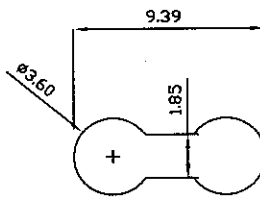

17558

0.394Kg/m

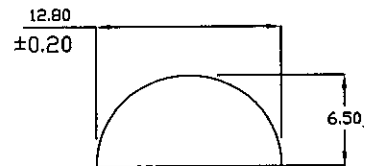

17555

0.800Kg/m

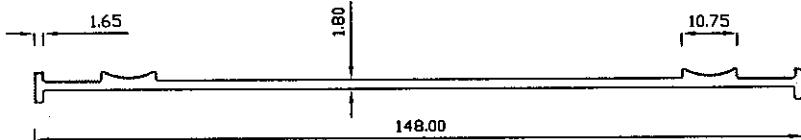

17561

0.152Kg/m

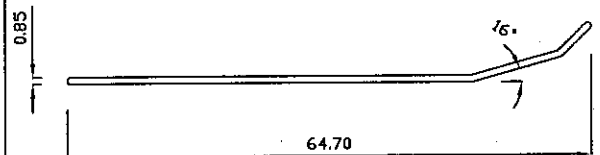

# EXTRUSION

# VALCO

## MISC SECTIONS

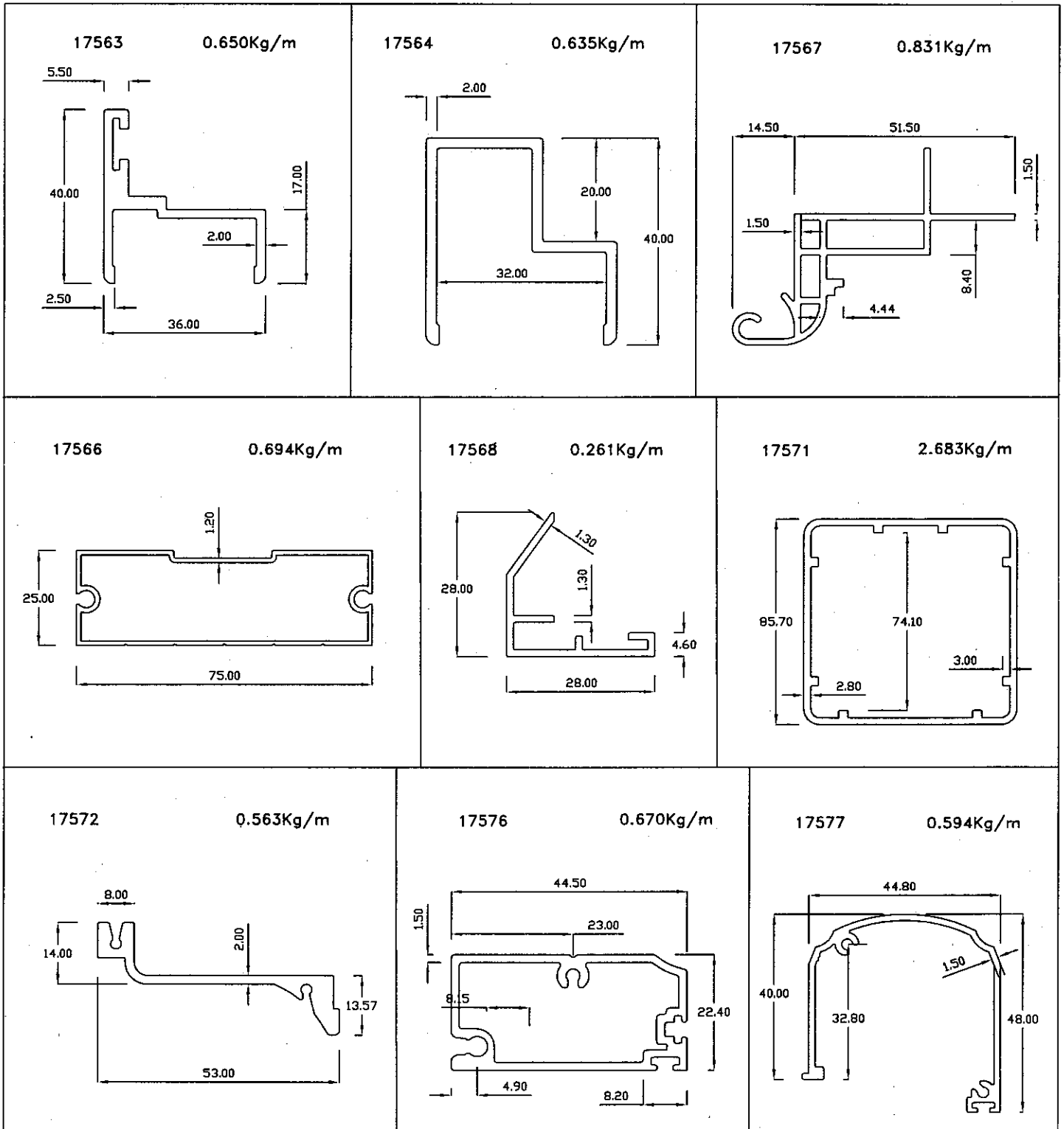

# EXTRUSION

# VALCO

## MISE SECTIONS

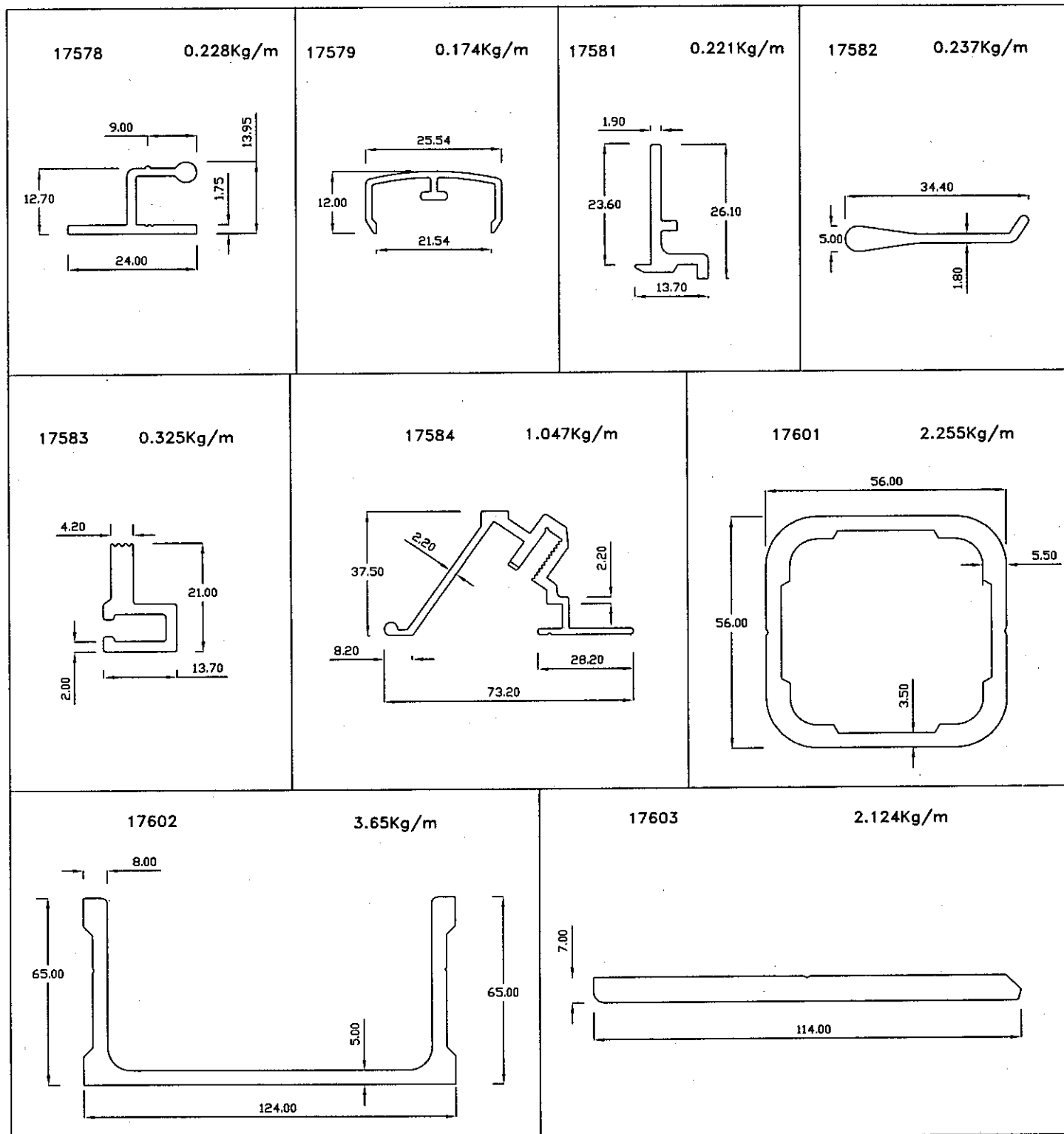

# EXTRUSION

# VALCO

## MISC SECTIONS

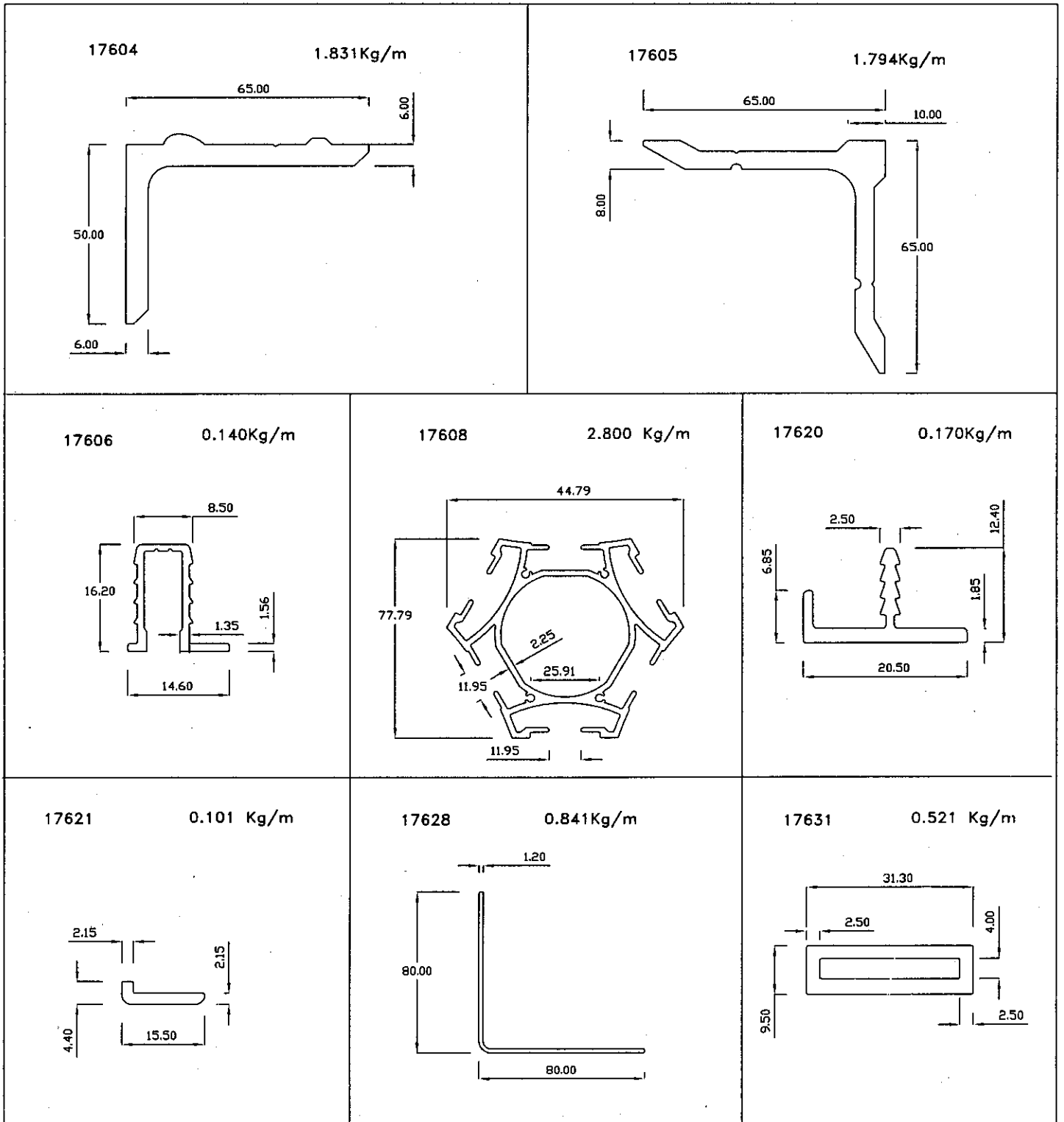

# EXTRUSION

# VALCO

## MISC SECTIONS

17637

0.658 Kg/m

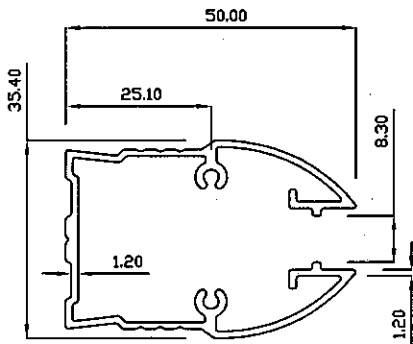

17644

0.800 Kg/m

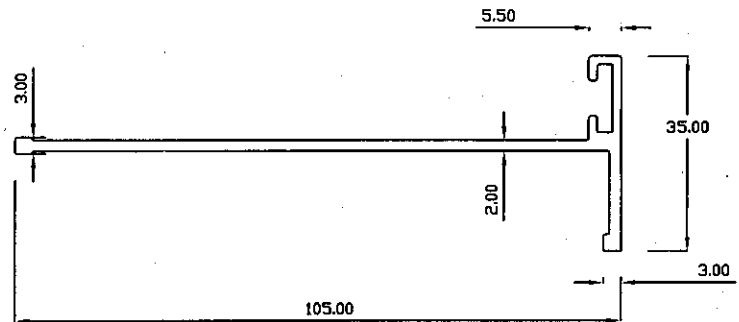

17656

0.475 Kg/m

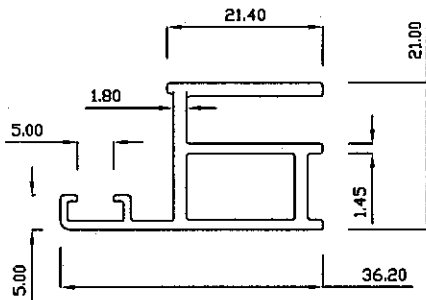

17657

0.321 Kg/m

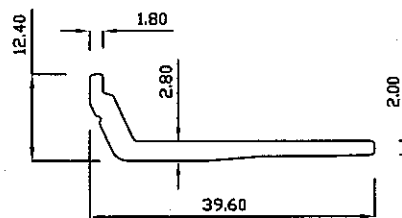

17658

0.600 Kg/m

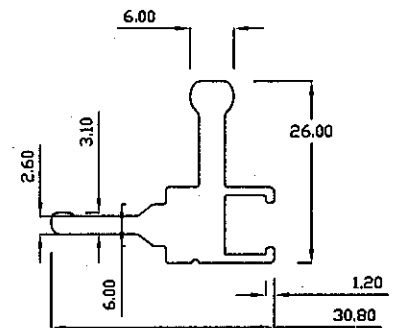

17659

0.626 Kg/m

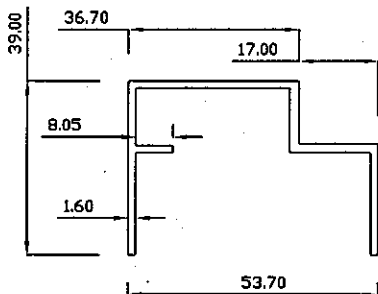

17664

0.380 Kg/m

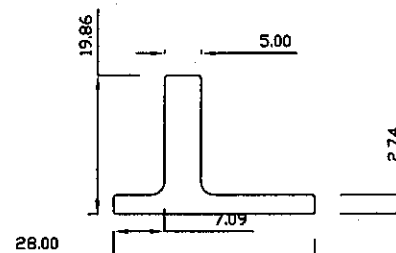

17665

0.432 Kg/m

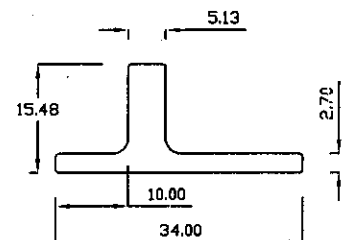

# EXTRUSION

# VALCO

## MISC SECTIONS

17666 0.256 Kg/m

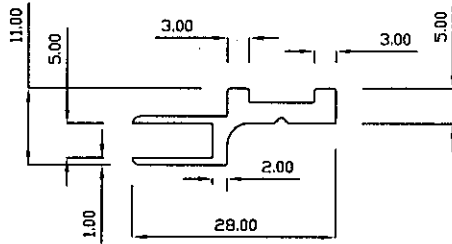

17667 1.200 Kg/m

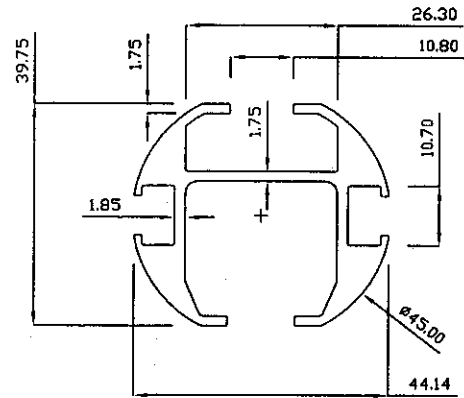

17668 1.128Kg/m

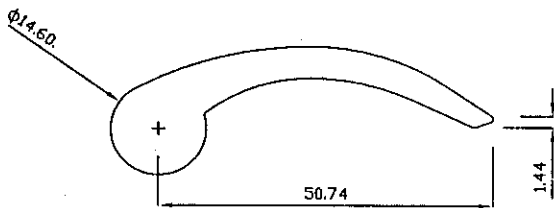

17669 1.533Kg/m

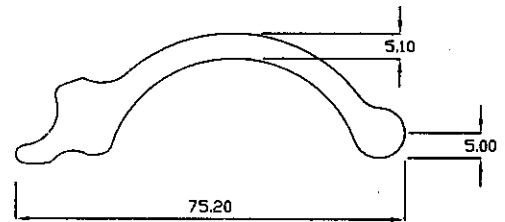

17670 1.733Kg/m

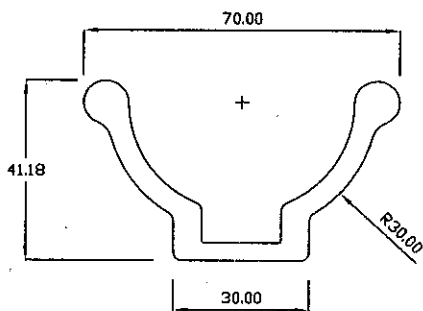

17671 0.667Kg/m

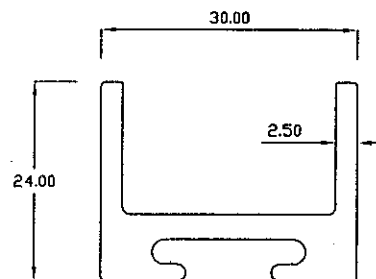

# EXTRUSION

# VALCO

## MISC SECTIONS

17672 0.540Kg/m

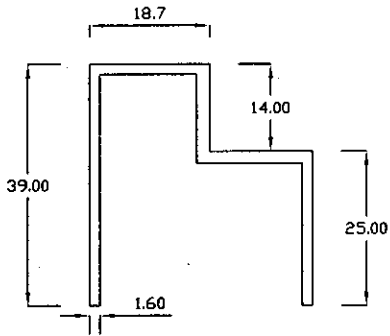

17673 0.540Kg/m

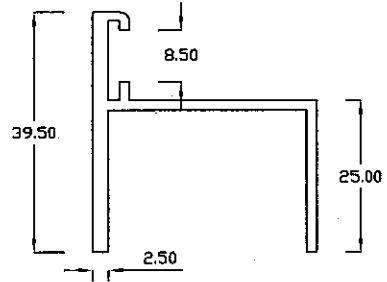

17674 1.728 Kg/m

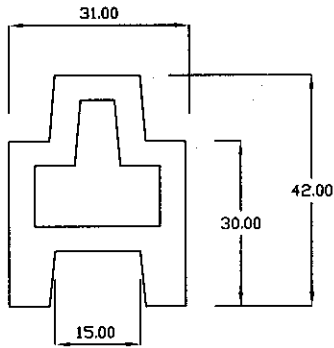

17675 0.214Kg/m

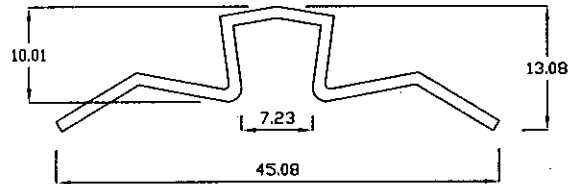

17677 0.205 Kg/m

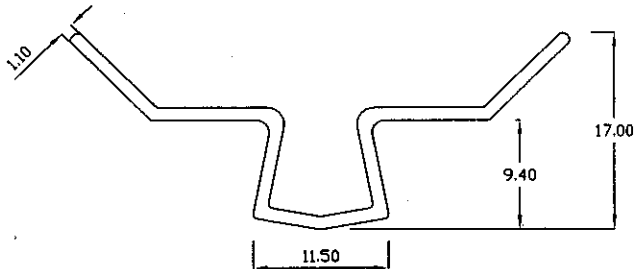

17678 0.270Kg/m

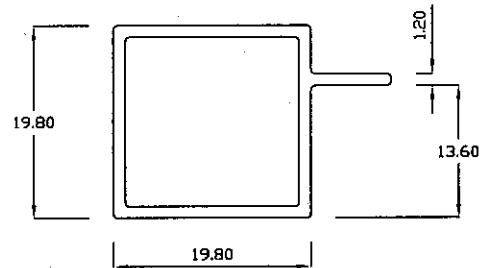

# EXTRUSION

# VALCO

## MISC SECTIONS

17699

0.515 Kg/m

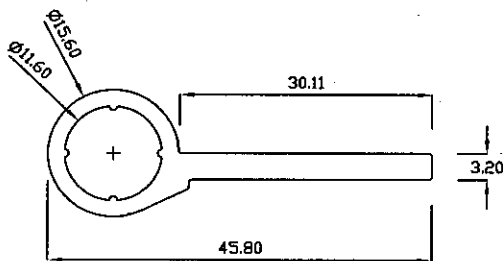

17700

0.840Kg/m

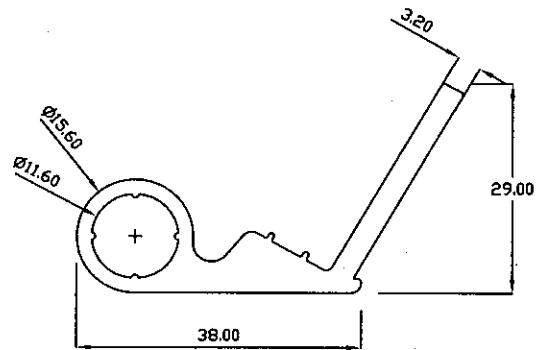

17703

0.842 Kg/m

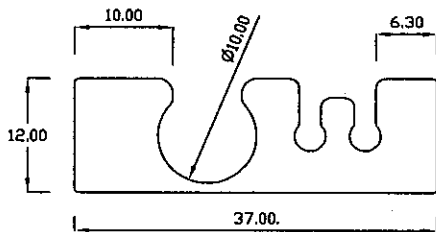

17704

0.236 Kg/m

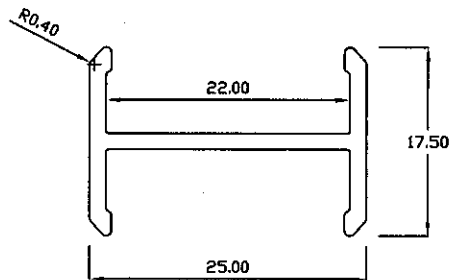

17707

0.150 Kg/m

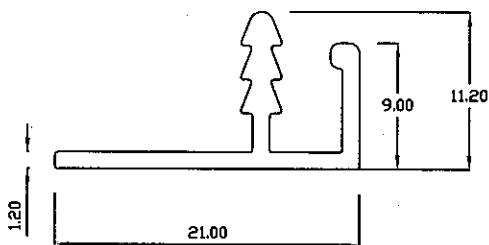

17708

0.407 Kg/m

